

## WaterPAK Series AeroPAK Dissolved Oxygen Controller

- **Reduce electricity consumption as much as 20%**
- **Improve effluent quality & help avoid permit violations**
- **Prevent under-aeration with continuous air adjustment**
- **Pre-engineered and preconfigured for multiple basins & blowers**
- **Automatic blower lead/lag function**
- **Application-specific installation & operation instructions**



Supplying dissolved oxygen to the aeration basins consumes a large part of your plant's electrical energy. AeroPAK is a pre-engineered control package designed to ensure continuous correct oxygen levels for maximum biological activity, while providing electricity savings and improving response to plant load changes. Implementing closed-loop DO control can result in as much as 20% reduction in electricity consumption.

AeroPAK provides closed-loop dissolved oxygen control for basins using diffused aeration and centrifugal blowers with Variable Speed Drives (VFD) or dampers. AeroPAK-1 provides control for a single basin with up to two blowers. AeroPAK-2 supports control for up to two basins with two blowers each, with independent parameters for each basin. Multiple AeroPAK controllers can be networked and connected to an HMI package for graphical operations, data acquisition and alarm/event logging.

AeroPAK allows selection of either basic dissolved oxygen control, or flow-paced control with dissolved oxygen trim. When the basic DO control is selected, the controller receives the dissolved oxygen signal from the DO analyzer, compares it to the local setpoint and generates an air demand output. The controller provides individual blower start/stop outputs and monitors the blower run status.

When the flow-paced strategy is selected, the controller receives the influent flow signal from the flow transmitter and uses the dissolved oxygen control loop output as a feedforward signal to modify the air demand signal. As the influent flow into the basin increases, the amount of air into the basin is increased proportionally, eliminating the delay between process measurement and correction normally associated with DO-only control.

Alarms are provided for low DO and loss of influent flow signal. The dissolved oxygen loop switches to manual mode and tracks a predetermined output value on loss of the DO signal. With the flow-paced strategy, loss of the flow signal will cause the controller to switch to the basic DO control strategy. This ensures continued aeration in the event of field sensor failure.

A blower lead/lag function determines the order in which the blowers start and run. If the lead blower is not capable of supplying sufficient air to meet the DO requirements, the controller starts the lag (second) blower. To ensure constant aeration, AeroPAK will automatically start the lag blower on failure of the lead blower (loss of Run contact). Indication of total blower runtime hours and on/off cycle counts is provided as preventive maintenance information.

The AeroPAK control station combines advanced multiloop control with powerful math and sequence control capability. It has a high-visibility, dot-matrix display with clear, informative screens for ease of operation. The basic device includes the CPU, power supply, terminal block, and operator display. The terminal block provides direct connection of field wiring at the rear of the control station. The power supply is 110/220Vac or 24Vdc. Serial communications are included as standard for connection to an HMI or SCADA system.

The AeroPAK control station is pre-engineered and preconfigured with all available control strategies. The user selects the desired strategy and enters basic setup information from the front panel. Operating displays for each basin include dissolved Oxygen loop control & operation, Dissolved Oxygen trend display and Influent Flow indication.

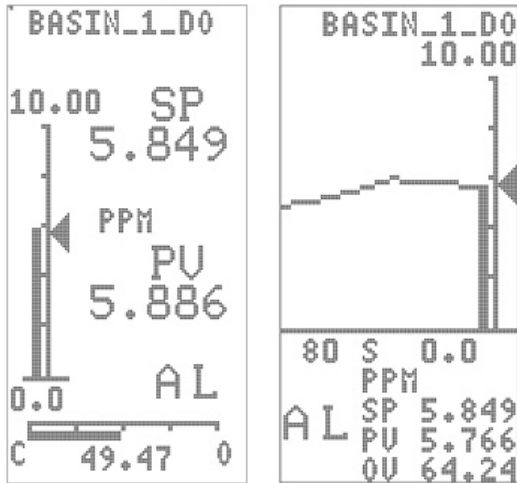

The Maintenance displays indicate blower status, lead/lag position, runtime and cycle count for each blower on each basin. An I/O status display shows the electrical value and status of analog and digital inputs and outputs for troubleshooting purposes.

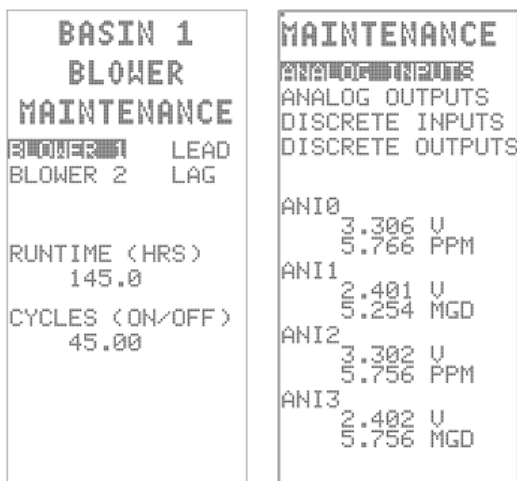

AeroPAK controllers are customized to each installation using a series of setup screens. Control strategy, number of blowers per basin, DO and influent ranges, engineering units, alarm trip points and tuning parameters are entered from the front display menus using the built-in keypad. A new tagname can also be easily assigned by the user.

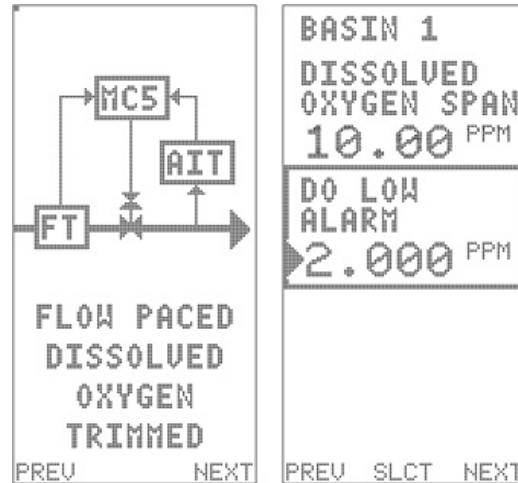

**AeroPAK OPTIONS**

**Dissolved Oxygen Analyzer and Probe** - AeroPAK will function with existing installed DO analyzers, or MicroMod can provide new equipment.

**Custom Application Engineering** - if the standard AeroPAK configuration doesn't meet your application needs or plant design, MicroMod can develop a cost-effective solution to improve your aeration efficiency and optimize your energy consumption.

**Plantwide System**

WaterPAK distills years of application experience into best-practice solutions to save our customers time and money. Plus, all the WaterPAK products can be integrated into a plantwide, Ethernet-based system with advanced operator stations, alarm/event logging and reporting. MicroMod provides the security of local dedicated control and operation together with the advantages of a PC-based control system, so you always have a window on the process.

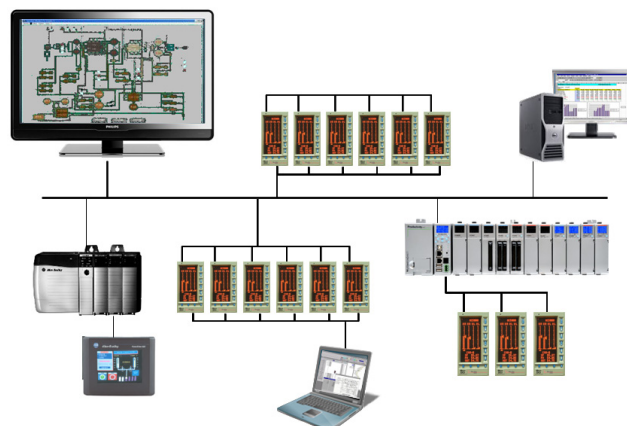

## **SPECIFICATIONS**

### **INPUTS AND OUTPUTS**

#### Analog Inputs (per basin)

Dissolved Oxygen  
Influent Flow

Signal Range: 0-20mA or 4-20mA linear or sq root

Resolution: 12 bit

Input Impedance: 1 megohm minimum for voltage inputs; value of ranging resistor for current signals.

Measurement Accuracy: +/-0.1% of span

(All analog inputs are referenced to signal common.)

#### Analog Outputs (per basin)

DO Demand - Blower #1

DO Demand - Blower #2

Signal Range: 0 - 21.84 mA dc (4 - 20 mA dc typically)

Load Resistance: 0-750 ohms

Accuracy: +/- 0.2% of span

#### Digital Inputs (per basin)

Blower #1 run status

Blower #2 run status

Discrete inputs internally powered with 4 volts @ 2 mA dc maximum

Permissible Contact Resistance: 100 ohm maximum

#### Digital Outputs (per basin)

Blower #1 Start/Stop

Blower #2 Start/Stop

Low DO alarm

Influent loss-of-signal alarm

Unpowered discrete solid state output.

Configuration: Single pole single throw, N.O., or N.C. referenced to power common.

Voltage: 30 V dc max.

Current: 50 mA dc max.

### **OPERATING CHARACTERISTICS**

#### Power Requirements:

21 to 28 VDC

120 VAC +/- 10%, 50/60 Hz

220/240 VAC +/- 10%, 50/60 Hz

#### Power Consumption:

AC Operation: 36 W max

#### Available Power Output for Transmitters:

24-26V dc, 80 mA, short circuit protected

#### Output Ripple: 200 mV p-p maximum

### **PHYSICAL CHARACTERISTICS**

#### Dimensions:

2 27/32"W x 5 21/32"H x 12 26/32"L

(72 mm W x 144 mm H x 305 mm L)

#### Panel Cutout: 2 11/16"W x 5 7/16"H

(68 mm W x 138 mm H)

#### Weight: 5 lbs. (approximate)

### **ENVIRONMENTAL CHARACTERISTICS**

Ambient Temperature Limits: 4 to 52°C (+40 to 125°F)

Relative Humidity Limits: 10 to 90% maximum

Temp. Effect on Accuracy: +/-0.28% per 28° (50°F) from reference temp. of 25°C (77°F)

Enclosure Classification: NEMA type 1/IEC 529 Type IP20

### **The WaterPAK Series**

**AeroPAK** is part of the **WaterPAK** series of pre-engineered control solutions for water and wastewater treatment plants. Other packages in the WaterPAK series include:

**PumpPAK** - For controlling pump speed and sequencing in lift stations, wet wells, influent and effluent flows

**FilterPAK** - Automatic control of filter bed operation and backwashing

### ORDERING INFORMATION

AeroPAK is a licensed package. The following end-user information must be supplied with each package ordered:  
End-user company name and complete address  
Contact Name  
Telephone and fax numbers

	AERO	05	06	07	B
	01 - 04				08
<b>AeroPAK</b> Dissolved Oxygen Controller	AERO				
<b>Functionality</b> 1 aeration basin 2 aeration basins	1 2				
<b>Power</b> 120-220Vac 24Vdc			1 2		
<b>Communication Option</b> Standard serial communications			0		
<b>Operator Language</b> English Spanish				E S	
<b>Design Level</b> Design Level					B

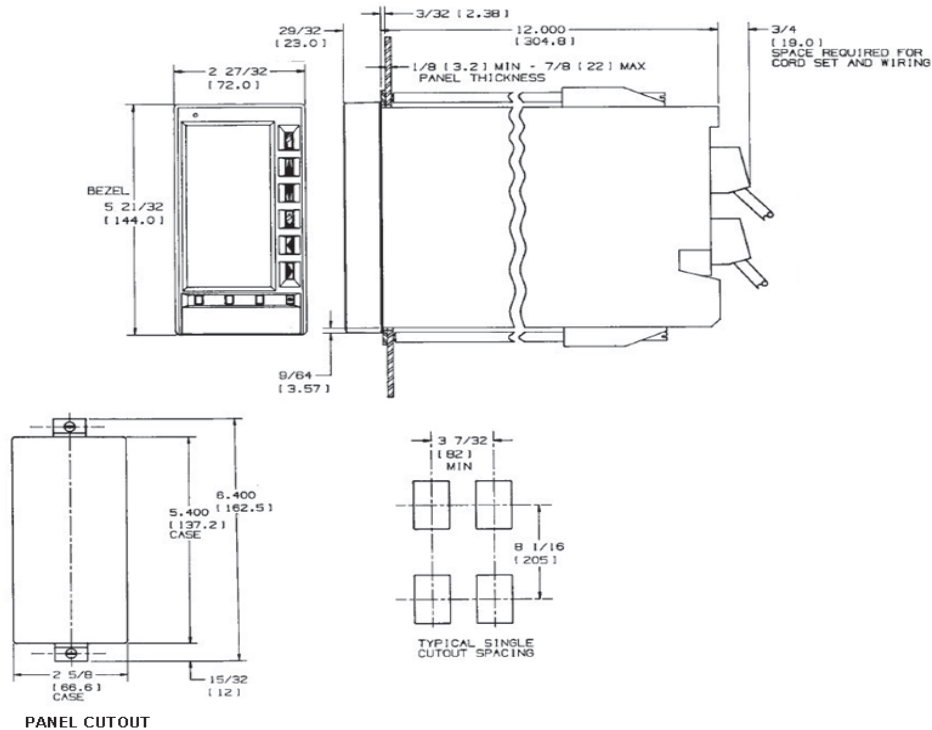

The Company's policy is one of continuous product improvement and the right is reserved to modify the information contained herein without notice.

Printed in USA September 2012

© MicroMod Automation, Inc. 2004



www.micromod.com

MicroMod Automation & Controls, Inc.  
3 Townline Circle  
Rochester, NY 14623-2537 USA  
Tel: (585) 321-9200  
Toll Free: 1-800-480-1975  
Fax: (585) 321-9291  
Email: sales@micromod.com